



Standard Siding Profile Specifications for Unmodified Hemlock | CVG

*Unmodified Hemlock should NOT BE USED for exterior siding application.
Intended use is soffits, ceilings and interior paneling.*

Table of Contents

Shiplap ½" Lap.....	2
Shiplap ¼" Reveal ½" Lap.....	3
Shiplap ⅛" Reveal ½" Lap.....	4
Square Edge Lap 1" Lap.....	5
Channel Rustic.....	6
Square Edge T&G ⅜" Tongue.....	7
Beveled T&G WP4 ⅜" Tongue.....	8
Square Edge.....	9
Tex Gap ¼" Reveal.....	10
Tex Gap ⅛" Reveal.....	11



Standard Siding Profile Specifications

SPECIES + GRADE:

Unmodified Hemlock | CVG

PROFILE: Shiplap | 1/2" Lap

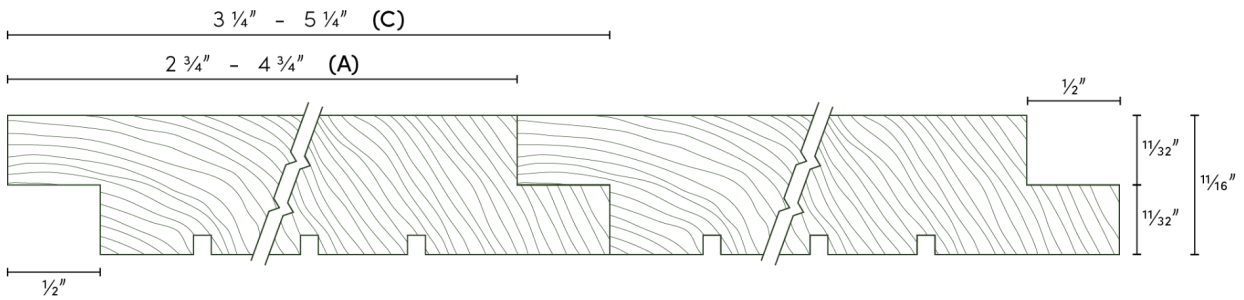

NOMINAL WIDTH	FACE (A)	REVEAL	FACE + REVEAL (B)	NET OVERALL WIDTH (C)
4"	2-3/4"	-	-	3-1/4"
6"	4-3/4"	-	-	5-1/4"



*Due to the inherent characteristics of natural wood, Montana Timber Products cannot guarantee against minor variations in milling tolerances.
 **Wider boards may exhibit a higher tendency for movement, cupping, and splitting. These are natural occurrences and not considered defects.
 ***"Custom 2" profiled material is available upon request. Please contact MTP for additional information.



Standard Siding Profile Specifications

SPECIES + GRADE:

Unmodified Hemlock | CVG

PROFILE: Shiplap | 1/4" Reveal | 1/2" Lap

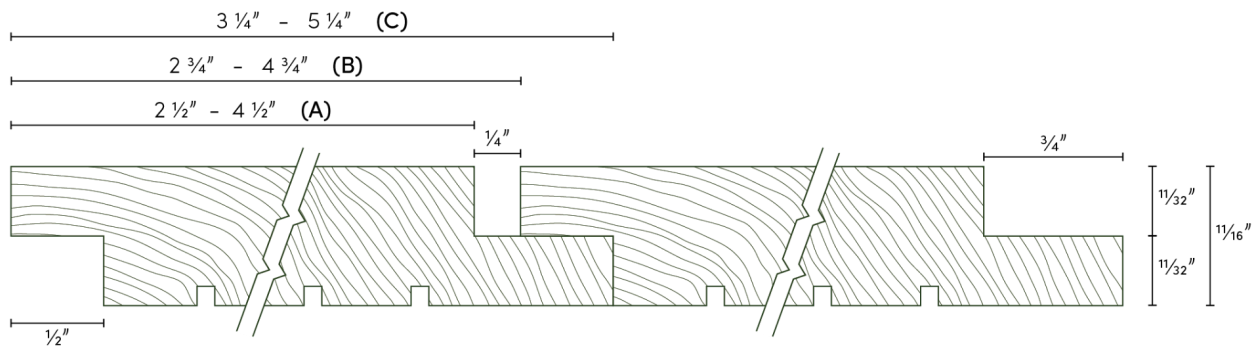

NOMINAL WIDTH	FACE (A)	REVEAL	FACE + REVEAL (B)	NET OVERALL WIDTH (C)
4"	2-1/2"	1/4"	2-3/4"	3-1/4"
6"	4-1/2"	1/4"	4-3/4"	5-1/4"



*Due to the inherent characteristics of natural wood, Montana Timber Products cannot guarantee against minor variations in milling tolerances.
 **Wider boards may exhibit a higher tendency for movement, cupping, and splitting. These are natural occurrences and not considered defects.
 ***Custom 2" profiled material is available upon request. Please contact MTP for additional information.



Standard Siding Profile Specifications

SPECIES + GRADE:

Unmodified Hemlock | CVG

PROFILE: Shiplap | 1/8" Reveal | 1/2" Lap

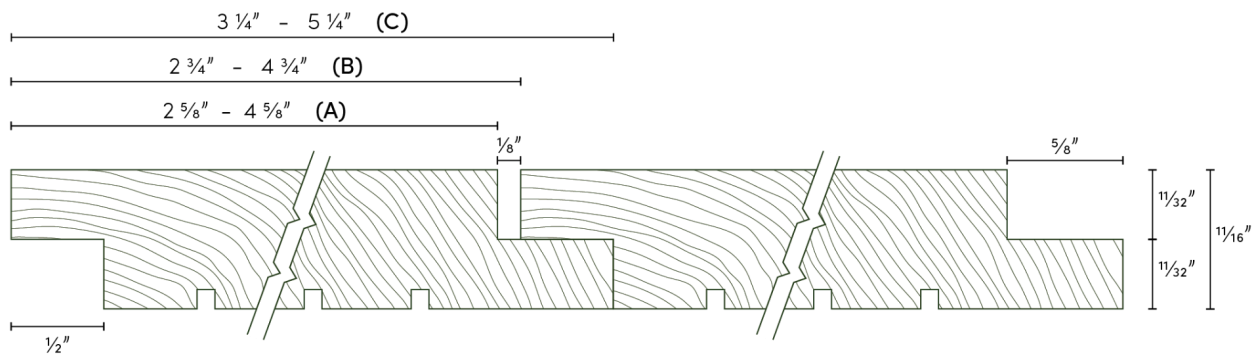

NOMINAL WIDTH	FACE (A)	REVEAL	FACE + REVEAL (B)	NET OVERALL WIDTH (C)
4"	2-5/8"	1/8"	2-3/4"	3-1/4"
6"	4-5/8"	1/8"	4-3/4"	5-1/4"

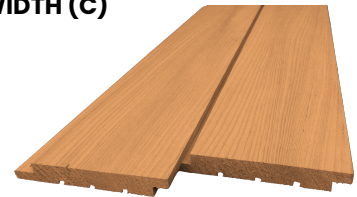

*Due to the inherent characteristics of natural wood, Montana Timber Products cannot guarantee against minor variations in milling tolerances.
 **Wider boards may exhibit a higher tendency for movement, cupping, and splitting. These are natural occurrences and not considered defects.
 ***Custom 2" profiled material is available upon request. Please contact MTP for additional information.



Standard Siding Profile Specifications

SPECIES + GRADE:

Unmodified Hemlock | CVG

PROFILE: Square Edge Lap | 1" Lap

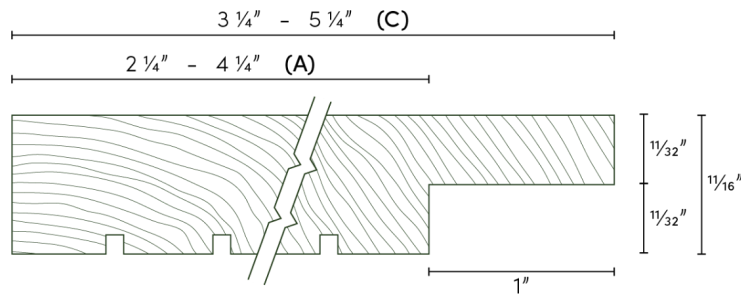

NOMINAL WIDTH	FACE (A)	REVEAL	FACE + REVEAL (B)	NET OVERALL WIDTH (C)
4"	2-1/4"	-	-	3-1/4"
6"	4-1/4"	-	-	5-1/4"



*Due to the inherent characteristics of natural wood, Montana Timber Products cannot guarantee against minor variations in milling tolerances.
 **Wider boards may exhibit a higher tendency for movement, cupping, and splitting. These are natural occurrences and not considered defects.
 ***"Custom 2" profiled material is available upon request. Please contact MTP for additional information.



Standard Siding Profile Specifications

SPECIES + GRADE:

Unmodified Hemlock | CVG

PROFILE: Channel Rustic

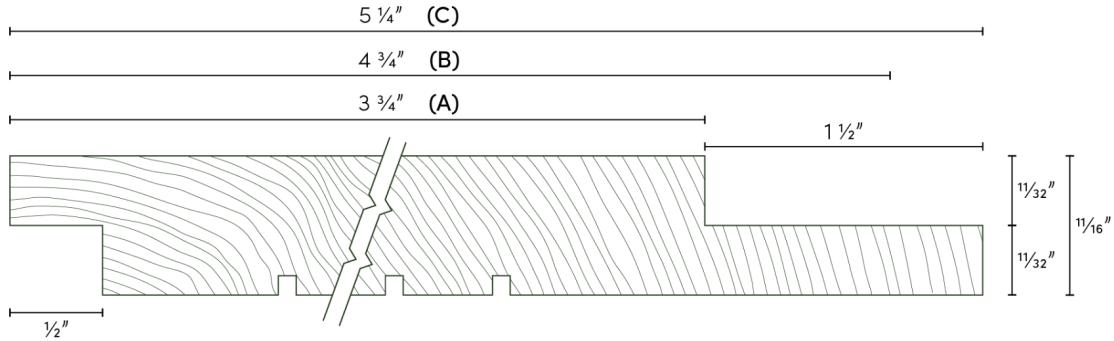

NOMINAL WIDTH	FACE (A)	REVEAL	FACE + REVEAL (B)	NET OVERALL WIDTH (C)
4"	Custom	Custom	Custom	3-1/4"
6"	3-3/4"	1"	4-3/4"	5-1/4"



*Due to the inherent characteristics of natural wood, Montana Timber Products cannot guarantee against minor variations in milling tolerances.
 **Wider boards may exhibit a higher tendency for movement, cupping, and splitting. These are natural occurrences and not considered defects.
 ***"Custom 2" profiled material is available upon request. Please contact MTP for additional information.



Standard Siding Profile Specifications

SPECIES + GRADE:

Unmodified Hemlock | CVG

PROFILE: Square Edge T&G | $\frac{3}{8}$ " Tongue

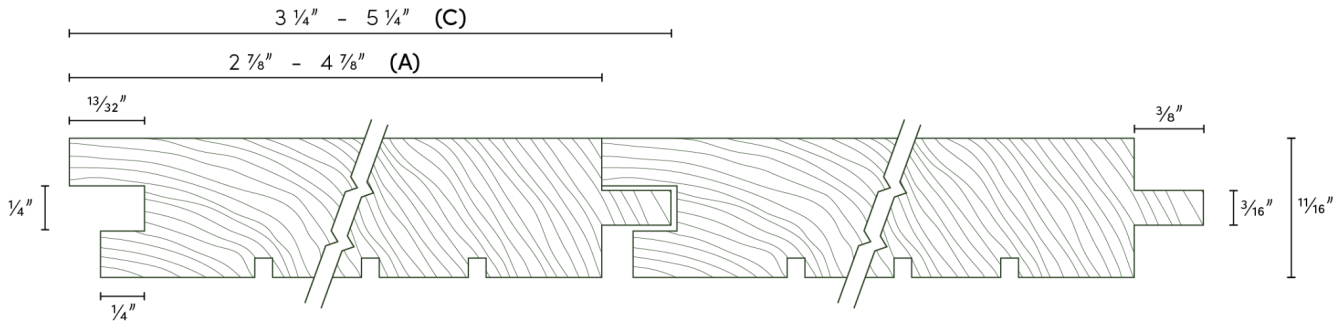

NOMINAL WIDTH	FACE (A)	REVEAL	FACE + REVEAL (B)	NET OVERALL WIDTH (C)
4"	2-7/8"	-	-	3-1/4"
6"	4-7/8"	-	-	5-1/4"



*Due to the inherent characteristics of natural wood, Montana Timber Products cannot guarantee against minor variations in milling tolerances.
 **Wider boards may exhibit a higher tendency for movement, cupping, and splitting. These are natural occurrences and not considered defects.
 ***"Custom 2" profiled material is available upon request. Please contact MTP for additional information.



Standard Siding Profile Specifications

SPECIES + GRADE:

Unmodified Hemlock | CVG

PROFILE: Beveled T&G | WP4 | 3/8" Tongue

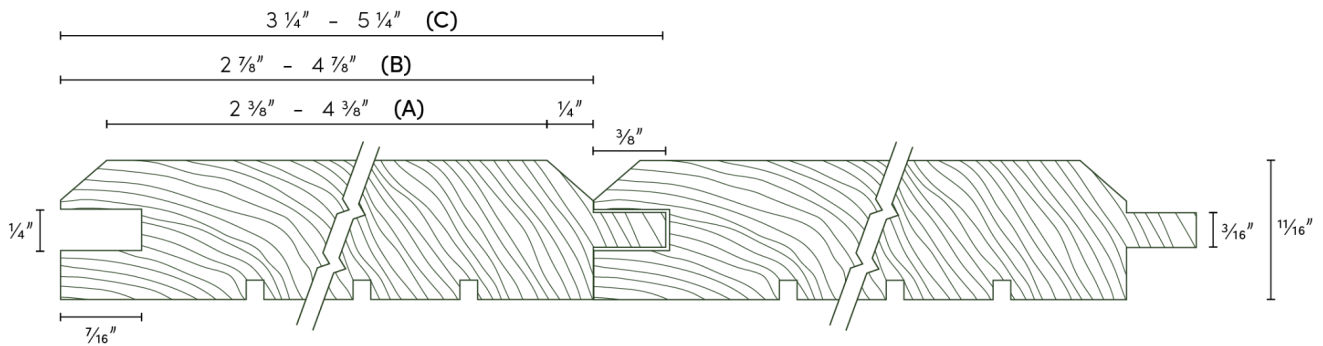

NOMINAL WIDTH	FACE (A)	REVEAL	FACE + REVEAL (B)	NET OVERALL WIDTH (C)
4"	2-3/8"	1/2"	2-7/8"	3-1/4"
6"	4-3/8"	1/2"	4-7/8"	5-1/4"

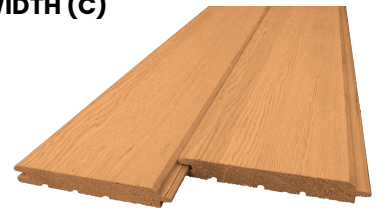

*Due to the inherent characteristics of natural wood, Montana Timber Products cannot guarantee against minor variations in milling tolerances.
 **Wider boards may exhibit a higher tendency for movement, cupping, and splitting. These are natural occurrences and not considered defects.
 ***Custom 2" profiled material is available upon request. Please contact MTP for additional information.



Standard Siding Profile Specifications

SPECIES + GRADE:

Unmodified Hemlock | CVG

PROFILE: Square Edge

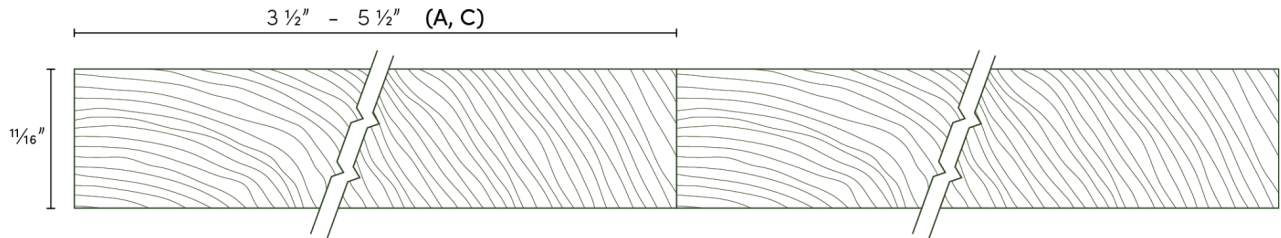

NOMINAL WIDTH	FACE (A)	REVEAL	FACE + REVEAL (B)	NET OVERALL WIDTH (C)
4"	3-1/2"	-	-	3-1/2"
6"	5-1/2"	-	-	5-1/2"



*Due to the inherent characteristics of natural wood, Montana Timber Products cannot guarantee against minor variations in milling tolerances.
 **Wider boards may exhibit a higher tendency for movement, cupping, and splitting. These are natural occurrences and not considered defects.
 ***"Custom 2" profiled material is available upon request. Please contact MTP for additional information.



Standard Siding Profile Specifications

SPECIES + GRADE:

Unmodified Hemlock | CVG

PROFILE: Tex Gap | 1/4" Reveal

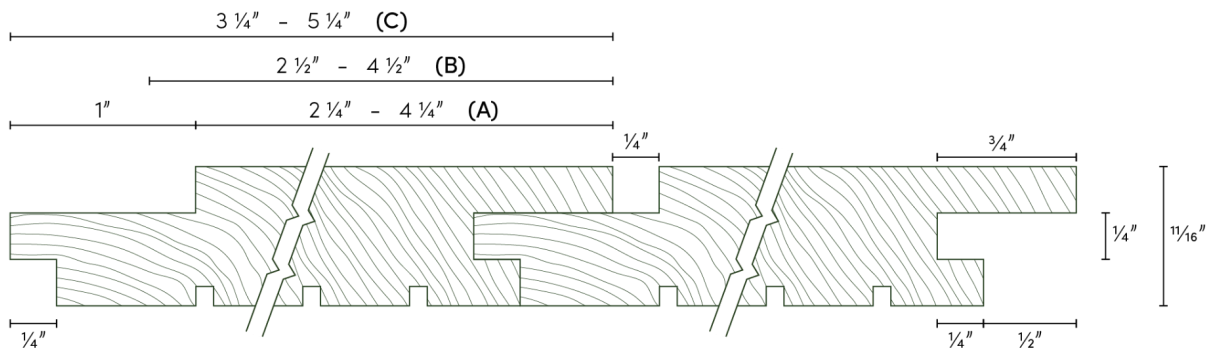

NOMINAL WIDTH	FACE (A)	REVEAL	FACE + REVEAL (B)	NET OVERALL WIDTH (C)
4"	2-1/4"	1/4"	2-1/2"	3-1/4"
6"	4-1/4"	1/4"	4-1/2"	5-1/4"

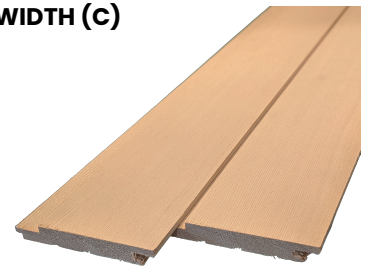

*Due to the inherent characteristics of natural wood, Montana Timber Products cannot guarantee against minor variations in milling tolerances.
 **Wider boards may exhibit a higher tendency for movement, cupping, and splitting. These are natural occurrences and not considered defects.
 ***Custom 2" profiled material is available upon request. Please contact MTP for additional information.



Standard Siding Profile Specifications

SPECIES + GRADE:

Unmodified Hemlock | CVG

PROFILE: Tex Gap | 1/8" Reveal

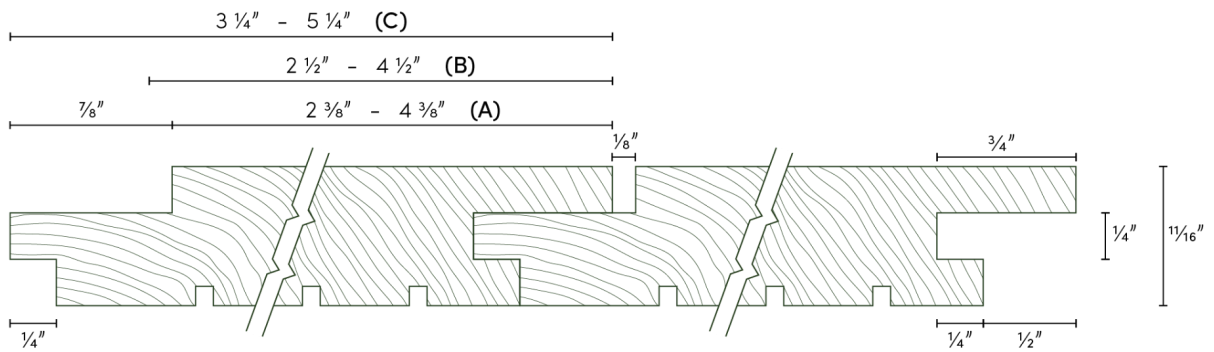

NOMINAL WIDTH	FACE (A)	REVEAL	FACE + REVEAL (B)	NET OVERALL WIDTH (C)
4"	2-3/8"	1/8"	2-1/2"	3-1/4"
6"	4-3/8"	1/8"	4-1/2"	5-1/4"

*Due to the inherent characteristics of natural wood, Montana Timber Products cannot guarantee against minor variations in milling tolerances.
 **Wider boards may exhibit a higher tendency for movement, cupping, and splitting. These are natural occurrences and not considered defects.
 ***Custom 2" profiled material is available upon request. Please contact MTP for additional information.